



ANALYTICAL SOLUTIONS

CONCENTRATE TABLES

METALLURGICAL

LABORATORY EQUIPMENT

SAMPLING

TURNKEY PROJECTS

PRODUCTIVITY IN MINERALS

MODEL ST-80

SPECIFICATION SHEET

Feed Capacity:	70 - 90kg/hr solids
Water Requirement:	950 l/hr
Water Pressure:	300 kPa
Motor:	0.75KW 4P 220/380V 50/60hz
Net Weight:	180kg

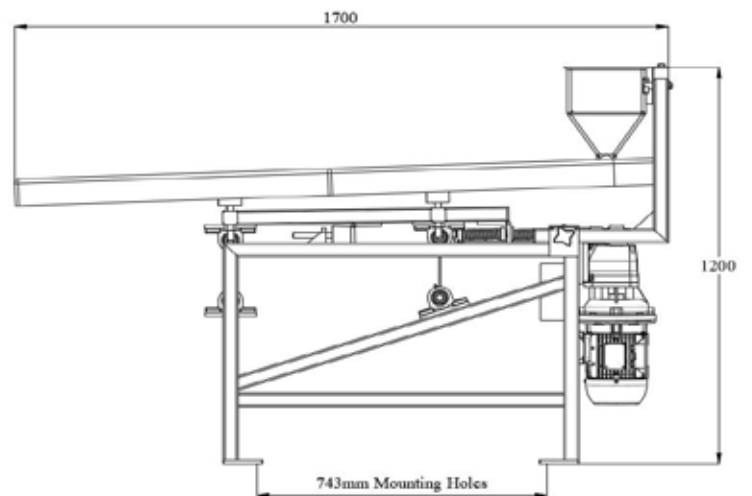
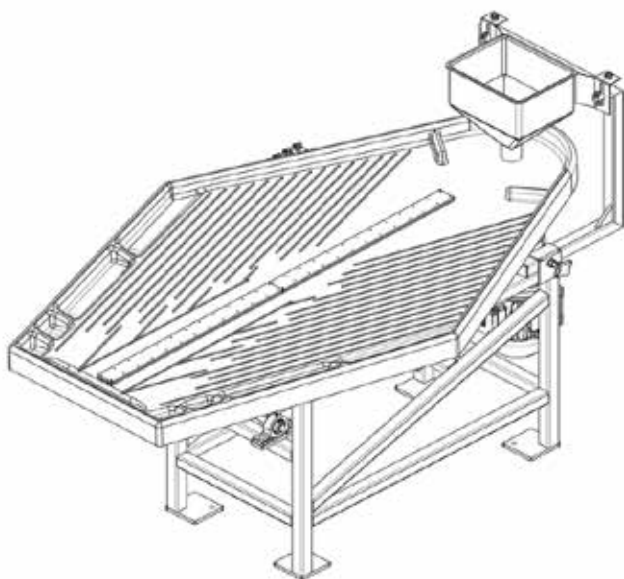
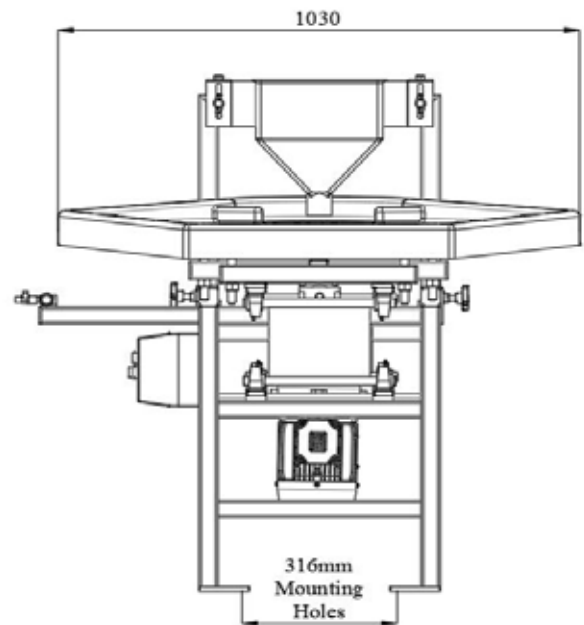
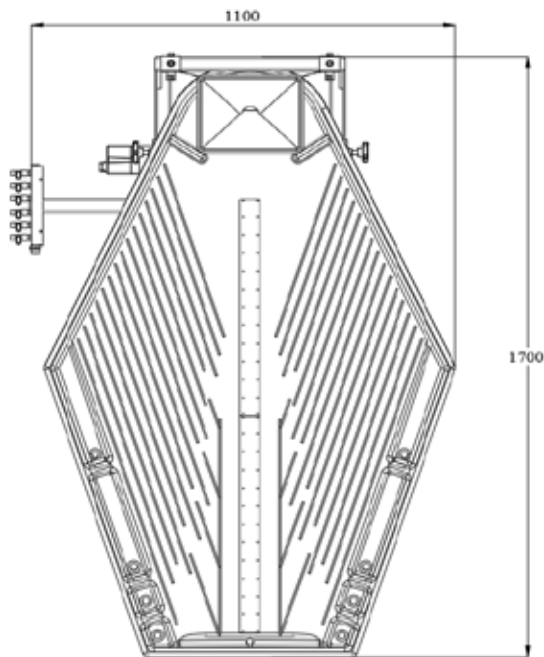

MIT-GROUP

MINERAL INNOVATIVE TECHNOLOGIES



THANK YOU FOR YOUR CONSIDERATION

METALLURGICAL

ANALYTICAL SOLUTIONS

LABORATORY EQUIPMENT

TURNKEY PROJECTS

SAMPLING

CONTACT US
Tel: 0861 500 108
Fax: 0866 138 322
Email: info@m-i-t.co.za
Website: www.m-i-t.co.za

