



**ANALYTICAL SOLUTIONS**

**CONCENTRATE TABLES**

**METALLURGICAL**

**LABORATORY EQUIPMENT**

**SAMPLING**

**TURNKEY PROJECTS**

**PRODUCTIVITY IN MINERALS**

# MODEL ST-700

# SPECIFICATION SHEET

<b>Feed Capacity:</b>	680 - 750kg/hr solids
<b>Water Requirement:</b>	2300 l/hr
<b>Water Pressure:</b>	300 kPa
<b>Motor:</b>	0.75KW 4P 220/380V 50/60hz
<b>Net Weight:</b>	300kg

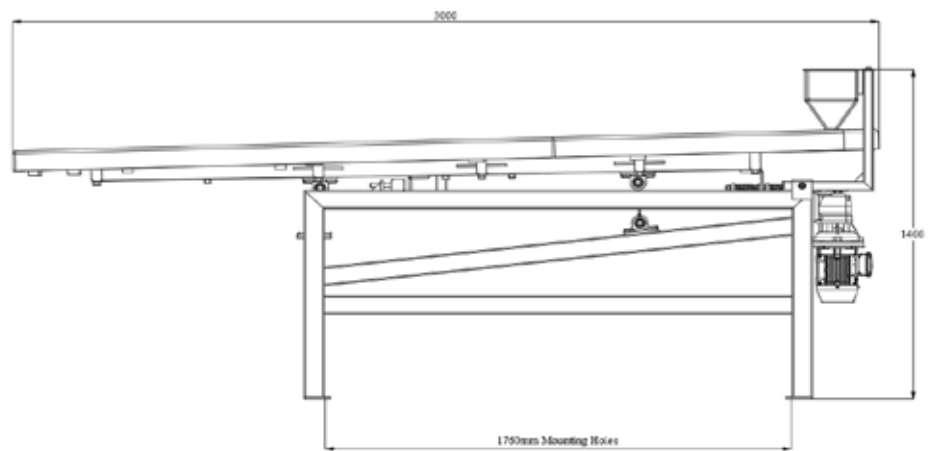
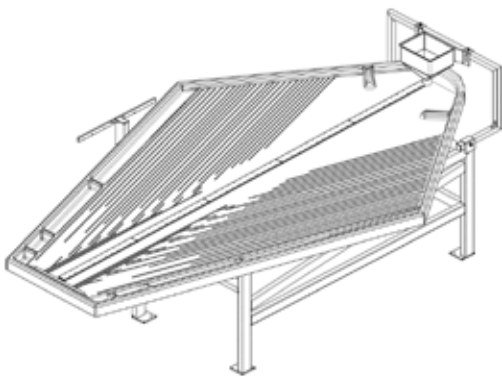
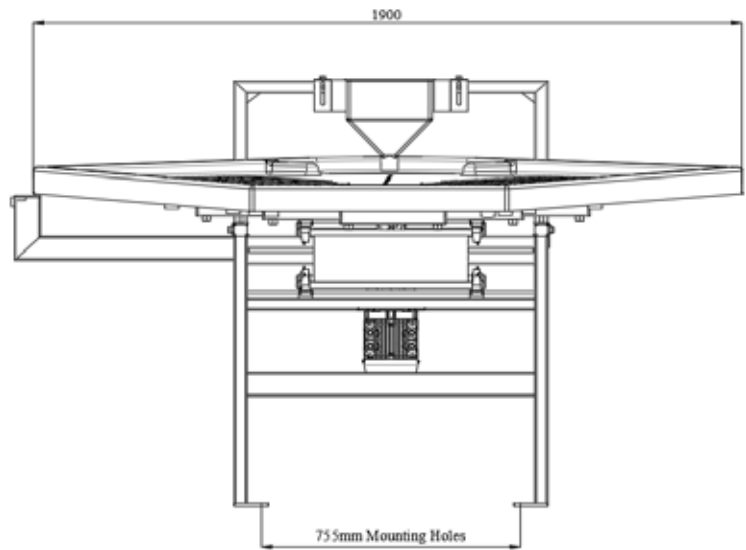
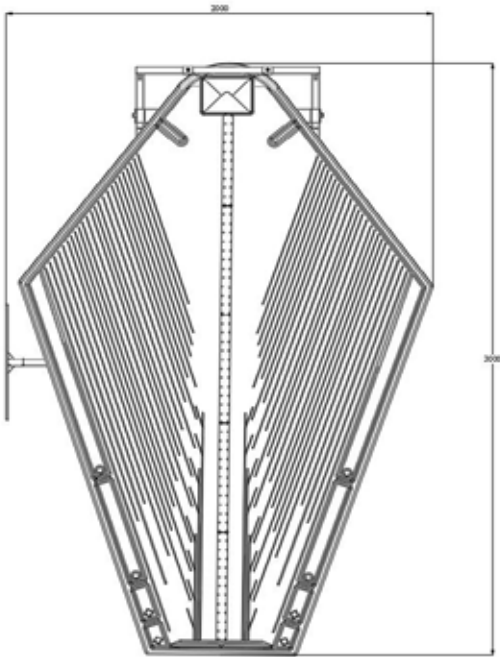

# MIT-GROUP

MINERAL INNOVATIVE TECHNOLOGIES



THANK YOU FOR YOUR CONSIDERATION

METALLURGICAL

ANALYTICAL SOLUTIONS

LABORATORY EQUIPMENT

TURNKEY PROJECTS

**CONTACT US**

Tel: 0861 500 108  
Fax: 0866 138 322  
Email: [info@m-i-t.co.za](mailto:info@m-i-t.co.za)  
Website: [www.m-i-t.co.za](http://www.m-i-t.co.za)

SAMPLING

